

1. Can You Follow Orders

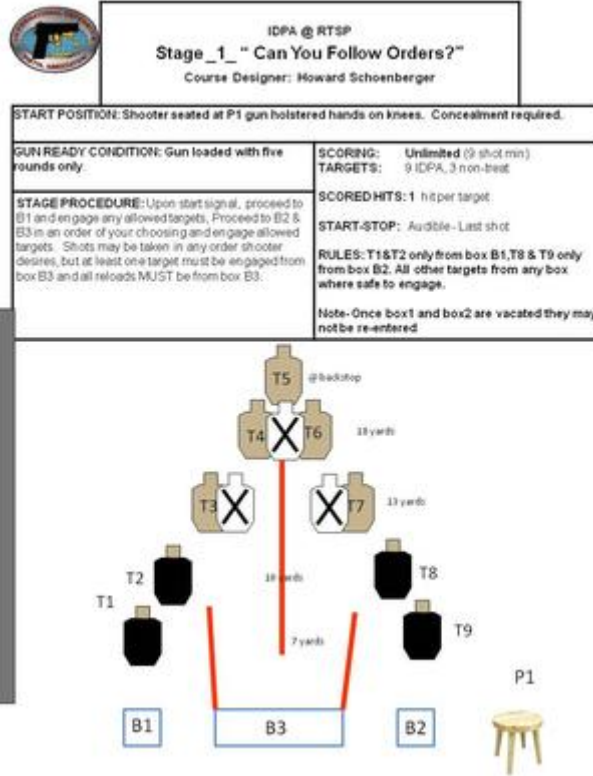

IDPA @ RTSP
Stage_1_ "Can You Follow Orders?"
 Course Designer: Howard Schoenberger

START POSITION: Shooter seated at P1 gun holstered hands on knees. Concealment required.

GUN READY CONDITION: Gun loaded with five rounds only.

STAGE PROCEDURE: Upon start signal, proceed to B1 and engage any allowed targets, Proceed to B2 & B3 in an order of your choosing and engage allowed targets. Shots may be taken in any order shooter desires, but at least one target must be engaged from box B3 and all reloads MUST be from box B3.

SCORING: Unlimited (9 shot min)

TARGETS: 9 IDPA, 3 non-heat

SCORED HITS: 1 hit per target.

START-STOP: Audible - Last shot

RULES: T1&T2 only from box B1, T8 & T9 only from box B2. All other targets from any box where safe to engage.

Note: Once box1 and box2 are vacated they may not be re-entered

Scoring	Unlimited	Firearm	Handgun	Rounds	9
Targets	9 paper, 3 no-shoot	Total	9 targets	Strings	1

Scenario & Procedure	Gun loaded with five rounds only. Upon start signal, proceed to B1 and engage any allowed targets, Proceed to B2 & B3 in an order of your choosing and engage allowed targets. Shots may be taken in any order shooter desires, but at least one target must be engaged from box B3 and all reloads MUST be from box B3. RULES: T1&T2; only from box B1, T8 & T9 only from box B2. All other targets from any box where safe to engage. Note- Once box1 and box2 are vacated they may not be re-entered
Start pos	Shooter seated at P1 gun holstered hands on knees, concealment required
Start on	Audible signal
Stop on	Last shot
Penalties	As per current edition of rules
Safety	L/R
Setup	

2. As easy as 3-2-1



IDPA @ RTSP
Stage_2_ "As easy as 3-2-1"
 Course Designer: Howard Schoenberger

START POSITION: Shooter standing at P1 facing P2 hands over ears. Concealment required.

<p>GUN READY CONDITION: Gun unloaded in holster, initial ammo feeding device on ground by your feet.</p> <p>STAGE PROCEDURE: Upon start signal, turn, pickup your ammo, draw and load gun then engage T1&T2 in tactical sequence with 3 rounds each from Retention! Retreat to P2 engaging T3 with two rounds using LEFT HAND ONLY. Proceed to P3 engaging T4 with 2 rounds RIGHT HAND ONLY. Proceed to P4, placing all remaining ammo feeding devices on chair, then open port and from a position of cover engage T5-T9 with one round each in tactical priority.</p>	<p>SCORING: Unlimited (15 shot min)</p> <p>TARGETS: 9 IDPA, 5 non-beat</p> <p>SCORED HITS: per stage procedure</p> <p>START-STOP: Audible - Last shot</p> <p>RULES: T1 & T2 may NOT be re-engaged once you leave P1.</p> <p>Note: PE earned if any shots fired with loaded ammo carriers on shooter's person at P4.</p>
---	---

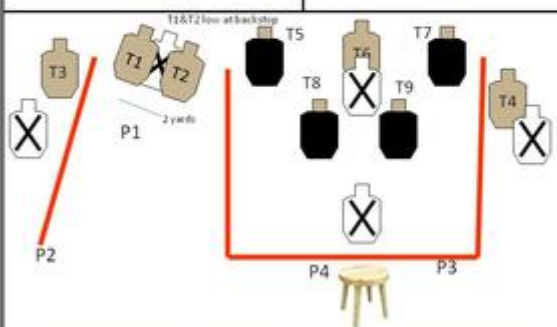

Scenario: You are surprised by 2 armed men in your yard and take them out from retention. You hear a noise around the fence and defend yourself from a third. Then another noise around your shed and you go to eliminate another thug. Feeling safe, you sit down at a table by your shed and start to take your ammo off to clean your gun. You open the shade to the shed to reach in for your cleaning kit and feed five armed intruders who mean you further harm.

Scoring	Unlimited	Firearm	Handgun	Rounds	15
Targets	9 paper, 5 no-shoot	Total	9 targets	Strings	1

Scenario & Procedure	Gun unloaded in holster, initial ammo feeding device on ground. Upon start signal, turn, pickup your ammo, draw and load gun then engage T1&T2; in tactical sequence with 3 rounds each from Retention! Retreat to P2 engaging T3 with two rounds using LEFT HAND ONLY. Proceed to P3 engaging T4 with 2 rounds RIGHT HAND ONLY. Proceed to P4, placing all remaining ammo feeding devices on chair, then open port and from a position of cover engage T5-T9 with one round each in tactical priority.
Start pos	Standing at P1 facing P2 hands over ears, concealment required.
Start on	Audible signal
Stop on	Last shot
Penalties	As per current edition of rules
Safety	L/R
Setup	

3. One, or maybe more?

IDPA @ RTSP
Stage_3 "One, or maybe more?"
 Course Designer: Howard Schoenberger

START POSITION: Shooter standing facing up range at start position P1 gun holstered hands over ears for each string. Concealment not required.

GUN READY CONDITION: Gun unloaded in holster slide closed. Initial magazine on chair.

STAGE PROCEDURE: Upon each start signal, turn, draw and load magazine from chair engage target(s) with one round only. At shooter's option they may reload and take follow up shot(s) on the target(s) for that string only.

String1 – 1 round in magazine engage T1 only.
 String2 – 2 rounds in magazine engage T2 & T3.
 String3 – 3 rounds in magazine engage T4-T5

SCORING: Unlimited (5 shot min)
TARGETS: 6 IDPA, 3 non-heat
Strings: 3 strings of fire

SCORED HITS: 1 hit per target
START-STOP: Audible - Last shot

Note: Bring extra ammo to line to reload first magazine as needed (off the clock)
 Gun will be cleared and holstered between strings.

Diagram details:
 - Backstop: @ backstop approx 22-25 yards
 - Targets: T1 (1 hit), T2 & T3 (2 hits), T4 & T5 (3 hits)
 - T2 T3: 10 yards
 - P1: at max safe distance from backstop

Scoring	Unlimited	Firearm	Handgun	Rounds	6
Targets	6 paper, 3 no-shoot	Total	6 targets	Strings	3

Scenario & Procedure	Shooter standing facing up range at start position P1 gun holstered with slide closed hands over ears for each string. Concealment not required. Upon each start signal, turn, draw and load magazine from chair engage target(s) with one round only. At shooter's option they may reload and take follow up shot(s) on the target(s) for that string only. String1 – 1 round in magazine engage T1 only. String2 – 2 rounds in magazine engage T2 & T3. String3 – 3 rounds in magazine engage T4-T5 Note- Bring extra ammo to line to reload first magazine as needed (off the clock) Gun will be cleared and holstered between strings.				
Start pos	Gun unloaded in holster slide closed. Initial magazine on chair.				
Start on	Audible signal				
Stop on	Last shot				
Penalties	As per current edition of rules				
Safety	L/R				
Setup					

4. All lined up



IDPA @ RTSP Stage_4_ "All lined up"

Course Designer: Howard Schoenberger

START POSITION: Shooter seated in chair facing down range hands above head, concealment required.	
GUN READY CONDITION: Gun loaded to division capacity and holstered.	SCORING: Limited (16 shots) TARGETS: 8 IDPA, 4 non-threat
STAGE PROCEDURE: Upon start signal, stand then draw then proceed to wall 1 or wall 2 and engage targets with 2 shots each in tactical priority, at least one head shot per target required. When finished proceed to other wall and repeat on second array, this time strong hand only. Reload as required.	SCORED HITS: 2 hits per target at least 1 headshot per target required. START-STOP: Audible - Last shot RULES: Targets T1-T4 must be engaged behind wall W1, while T5-T8 from behind Wall W2 Note: only one body shot per target will count as a hit.

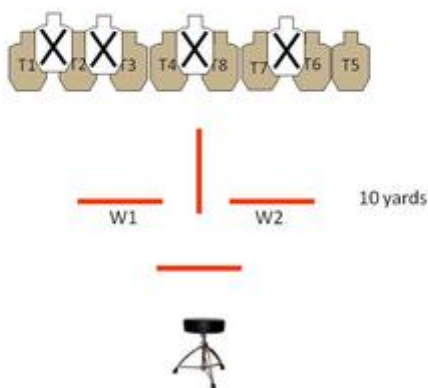

Scoring	Limited	Firearm	Handgun	Rounds	16
Targets	8 paper, 4 no-shoot	Total	8 targets	Strings	1

Scenario & Procedure	START POSITION: Shooter seated in chair facing down range hands above head, concealment not required. Upon start signal, stand then draw then proceed to wall 1 or wall 2 and engage targets with 2 shots each in tactical priority, at least one head shot per target required. When finished proceed to other wall and repeat on second array, this time strong hand only. Reload as required. RULES: Targets T1-T4 must be engaged behind wall W1, while T5-T8 from behind Wall W2 Note- only one body shot per target will count as a hit.
Start pos	Gun loaded to division capacity and holstered.
Start on	Audible signal
Stop on	Last shot
Penalties	As per current edition of rules
Safety	L/R
Setup	