

# 1. Rifle Augusti #1

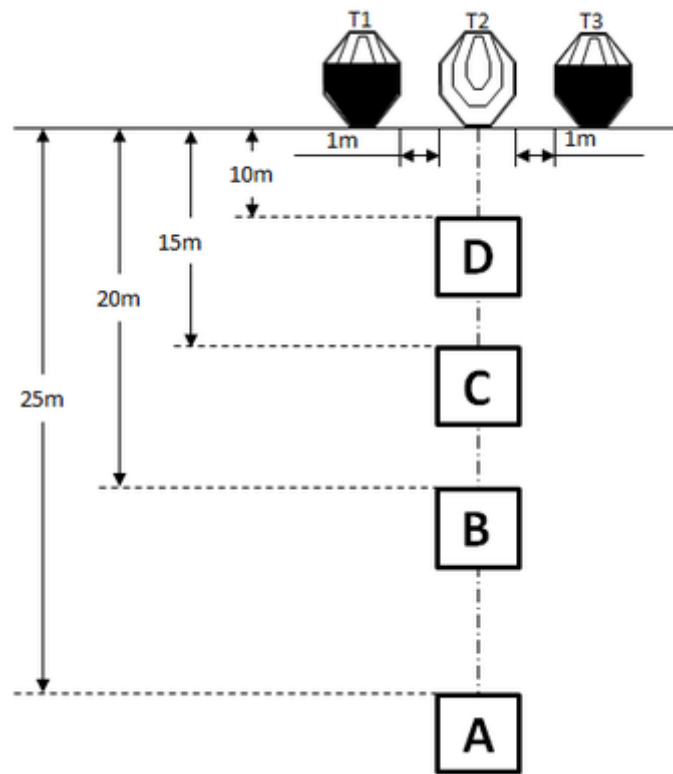

CoF	Comstock - Long	Points	120 p
Targets	3 paper, Total 3 targets	Min rounds	24
Firearm	Rifle	Match-%	36.36%

Procedure	After the audible start signal engage targets with a minimum of two rounds each from within area "A". Then move to area "B" and engage targets with a minimum of two rounds each. Then move to area "C" and engage targets with a minimum of two rounds each. Then move to area "D" and engage targets with a minimum of two rounds each.
Starting position	Standing erect in area "A", stock touching the competitor at hip level.
Firearm ready condition	Loaded (Option 1).
Start on	Audible signal
Stop on	Last shot
Penalties	As per current edition of rules
Safety angles	L/R
Setup notes	

## 2. Rifle Augusti #2

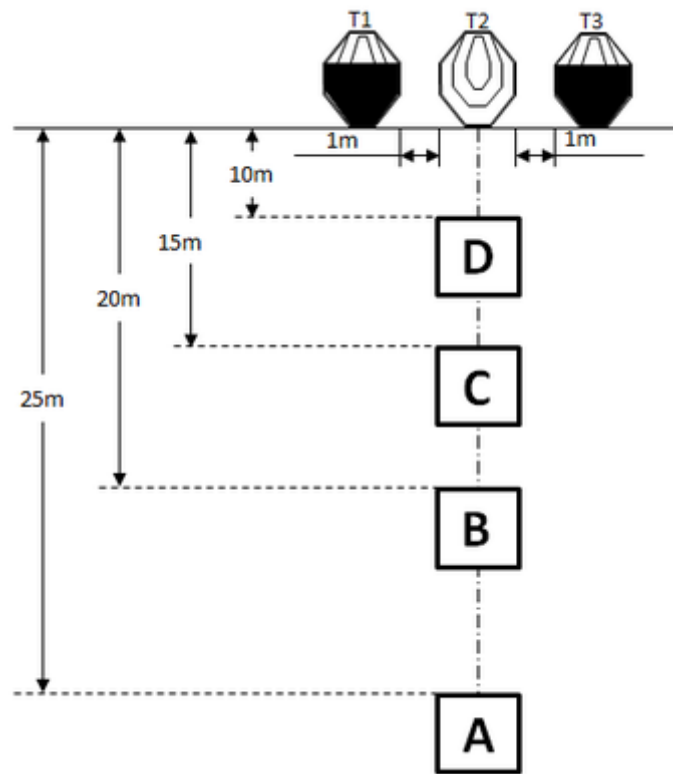

CoF	Comstock - Long	Points	120 p
Targets	3 paper, Total 3 targets	Min rounds	24
Firearm	Rifle	Match-%	36.36%

Procedure	After the audible start signal engage targets with a minimum of two rounds each from within area "D". Then move to area "C" and engage targets with a minimum of two rounds each. Then move to area "B" and engage targets with a minimum of two rounds each. Then move to area "A" and engage targets with a minimum of two rounds each. Start position: Standing erect in area "D", stock touching the competitor at hip level.
Starting position	Standing erect in area "D", stock touching the competitor at hip level.
Firearm ready condition	Loaded (Option 1).
Start on	Audible signal
Stop on	Last shot
Penalties	As per current edition of rules
Safety angles	L/R
Setup notes	

### 3. Rifle Augusti #3

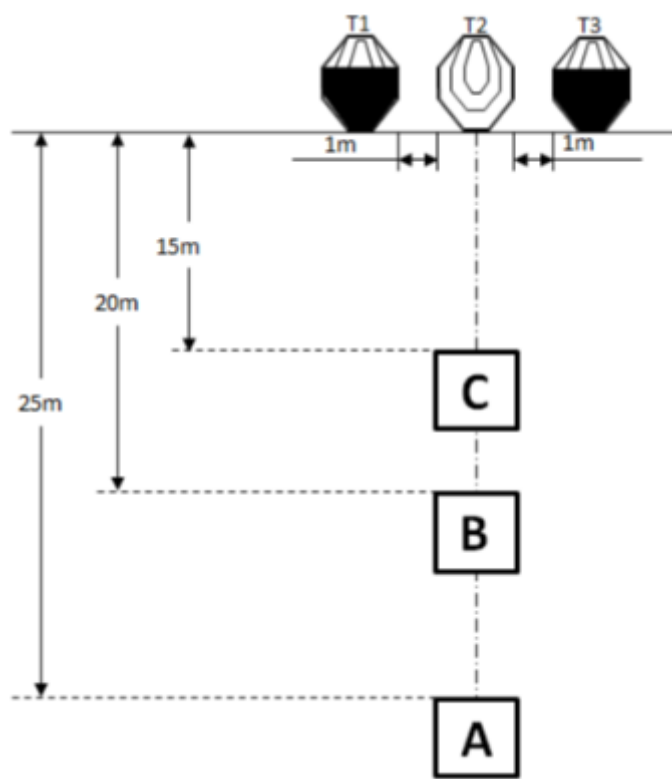

CoF	Comstock - Medium	Points	90 p
Targets	3 paper, Total 3 targets	Min rounds	18
Firearm	Rifle	Match-%	27.27%

Procedure	After the audible start signal engage target T1 with a minimum of six rounds from within area "A". Then move to area "B" and engage target T2 with a minimum of six rounds. Then move to area "C" and engage target T3 with a minimum of six rounds.
Starting position	Standing erect in area "A", stock touching the competitor at hip level.
Firearm ready condition	Loaded (Option 1).
Start on	Audible signal
Stop on	Last shot
Penalties	As per current edition of rules
Safety angles	L/R
Setup notes	