

1. Santa's Diamond

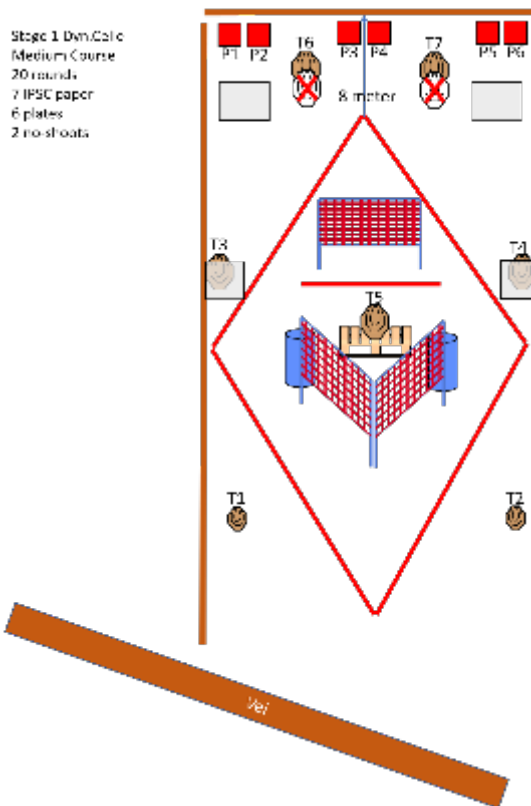

CoF	Comstock - Long	Points	105 p
Targets	8 paper, 5 plates, 2 no-shoot, Total 13 targets	Min rounds	21
Firearm	Rifle	Match-%	23.08%

Procedure	At start signal engage all targets from within the designated area
Starting position	
Firearm ready condition	Option 1 loaded
Start on	Audible signal
Stop on	Last shot
Penalties	As per current edition of rules
Safety angles	L/R
Setup notes	

2. Santa's T-run

Stage 2: 360 Cella
 Short Course
 5 miniskiver
 10 rounds

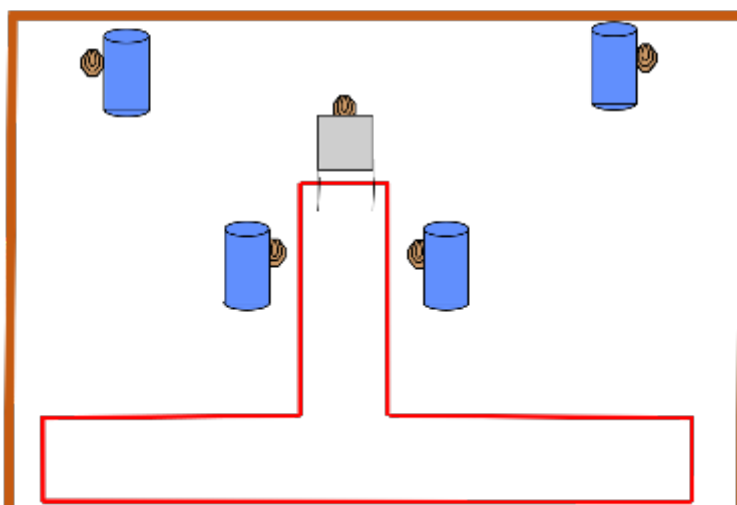

CoF	Comstock - Short	Points	50 p
Targets	5 paper, Total 5 targets	Min rounds	10
Firearm	Rifle	Match-%	10.99%

Procedure	At start signal engage all targets from within the demarcated area. NB Muzzle of a loaded rifle must at all time be pointed below the berm. Pointing over the berm will result in a DQ, unsafe gunhandling.
Starting position	
Firearm ready condition	Option 1 - Loaded
Start on	Audible signal
Stop on	Last shot
Penalties	As per current edition of rules
Safety angles	L/R
Setup notes	

3. Santa's Jinglebells

Stage3,
Medium Course
Poppers (Non-Standard)
5 lpsc: papp

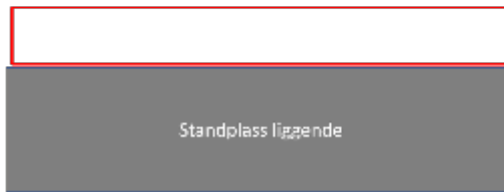
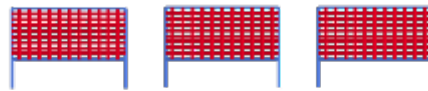

CoF	Comstock - Medium	Points	100 p
Targets	5 paper, 10 popper, Total 15 targets	Min rounds	20
Firearm	Rifle	Match-%	21.98%

Procedure	At start signal engage all targets from within the demarcated area. "Poppers" are steel bowling pins
Starting position	
Firearm ready condition	Option 1 - Loaded
Start on	Audible signal
Stop on	Last shot
Penalties	As per current edition of rules
Safety angles	L/R
Setup notes	

4. Santa's Cradle

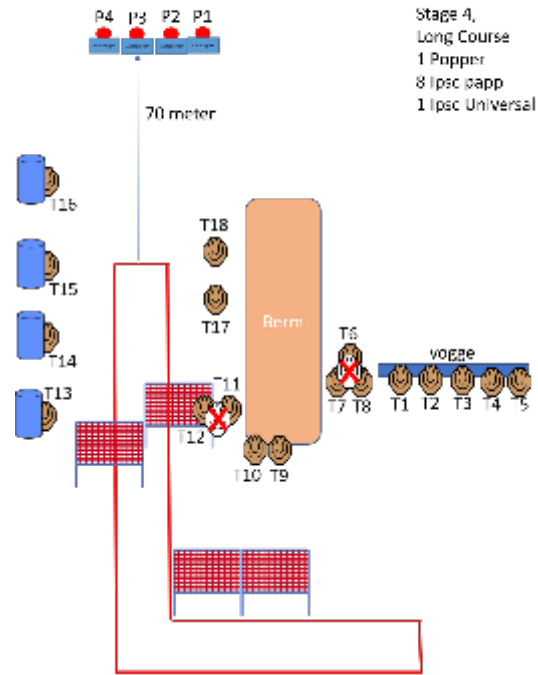

CoF	Comstock - Long	Points	200 p
Targets	18 paper, 4 plates, 2 no-shoot, Total 22 targets	Min rounds	40
Firearm	Rifle	Match-%	43.96%

Procedure	At start signal engage all targets from within the demarcated area. Cradle is released at startsignal.
Starting position	
Firearm ready condition	Option 1 - Loaded
Start on	Audible signal
Stop on	Last shot
Penalties	As per current edition of rules
Safety angles	L/R
Setup notes	